



PCU6.3-F



PCU6.1-F



PCU6.1-P



PCU6.3-P



PCU6.1-S

# Installation manual

## Safera Airis Stove Guard



We sense what humans don't

# 1. Preparations

## Contents

1. Preparations
2. Installation
3. Installation troubleshooting
4. Manual adjustment mode
5. Optional features
  - AUX-connection
  - Water leakage sensor

Follow these instructions carefully and pay particular attention to the instructions marked in the following way:

### ▲ WARNING

Follow instructions marked with a warning accurately to prevent injury to persons and damage to property.

### ▮ ATTENTION

Follow instructions marked with a note carefully to prevent damage to property.

### 📖 HINT

Hints give you useful advices on using the appliance.

## Warnings

### ▲ WARNING

Read user and installation manual before using or installing the appliance.

Install and check the application according to the instructions. Safera is not liable for any damages or expenses caused by inappropriate installation.

### ▲ WARNING

Check that the Stove Guard is compatible with the cooker (see section 1.1).

If the network cable is damaged, it must be replaced by the service personnel of the manufacturer or their representative to avoid hazards.

All electrical connections must be carried out by a qualified electrician.

### ▮ ATTENTION

If the appliance was stored in a cold space, it must be allowed to warm up to room temperature before connecting it to electric network.

## 1.1 Compatibility

Safera Stove Guard is compatible with most electrical cookers, hobs and ovens meant for household use:

- Traditional cast-iron cookers and hobs
- Ceramic cookers and hobs
- Induction cookers and hobs
- Cookers and hobs equipped with a timer, afterheat indicator, child proof lock or integrated switch-off system

Safera Airis is compatible with cookers no wider than 90 cm, see chapter 2. Installation step 2/2.

## 1.2 Package content

Check the product and the contents of the package before installation:

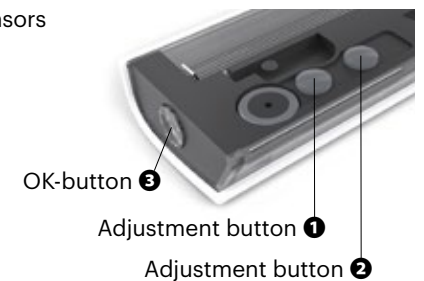
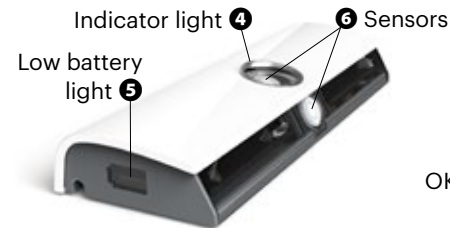
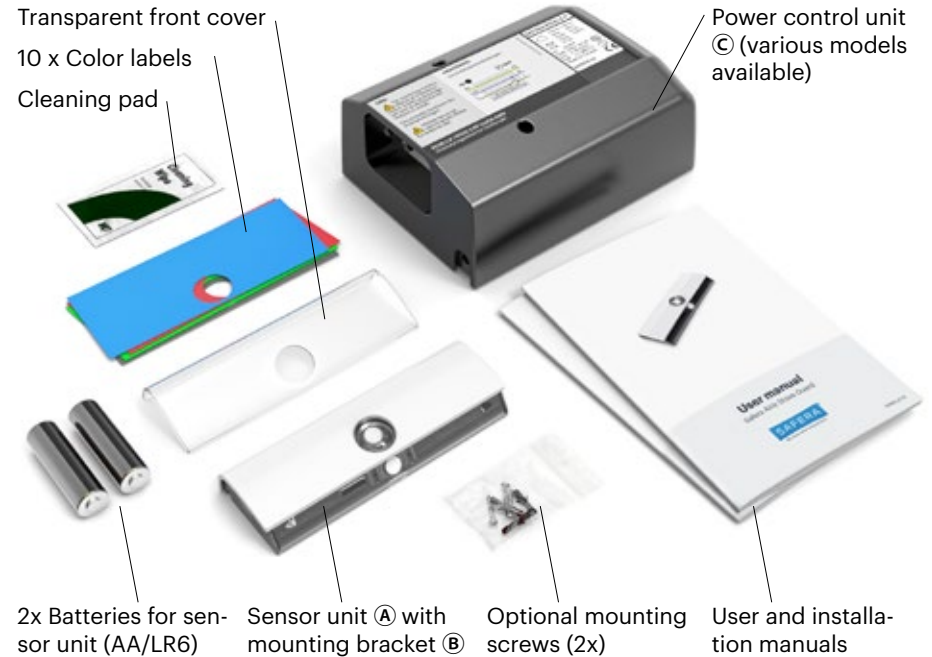

### ▲ WARNING

Please contact your vendor if you notice anything unusual about the appliance.

Install the power control unit © according to the following instructions.

## PCU6.3-F

Fixed 3-phase connection.  
See pages 6-7.



## PCU6.3-P

Perilex-connectors.  
See pages 8-9.



## PCU6.1-F

Fixed 1-phase connection.  
See pages 10-11.



## PCU6.1-P

1-phase, 3-pin plug OUT.  
See pages 12-13.



## PCU6.1-S

Schuko-connectors.  
See pages 14-15.



## PCU6.3-F - Installation

Fixed 3-phase connection.

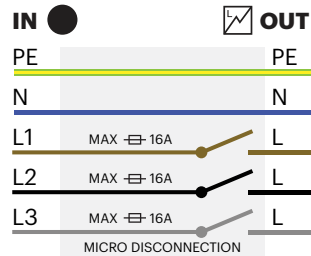
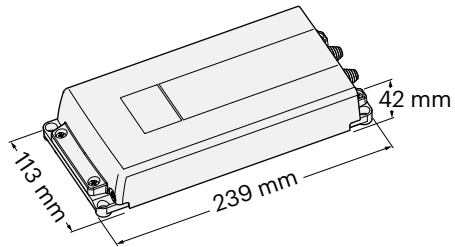
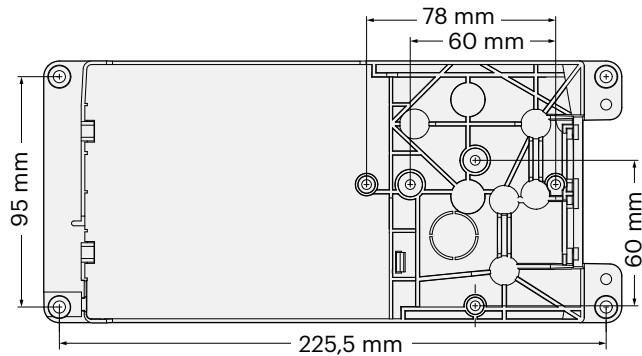

### ▲ WARNING

Make sure that there is no power supply to the cooker and the oven by removing their fuses. Also ensure that the cooker is switched off.

OUT-wires are always energized when the power control unit is connected to the electrical network. If a wire is loose, it must be properly covered.

Do not install the power control unit to excessive heat: See operational ambient temperature on the power control unit ©.

### ⚠ ATTENTION

Install the power control unit © so that it is not exposed to moisture. Check that all cables can move freely.

If you are replacing the cooker or the power control unit, see chapter 4 manual adjustment mode.

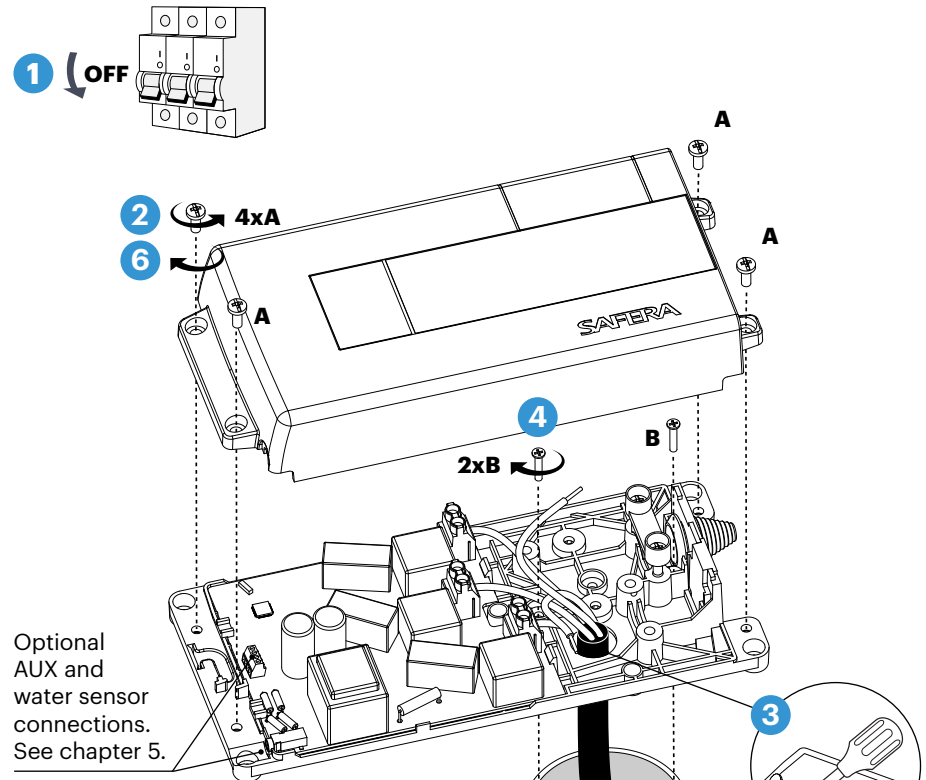

Optional AUX and water sensor connections. See chapter 5.

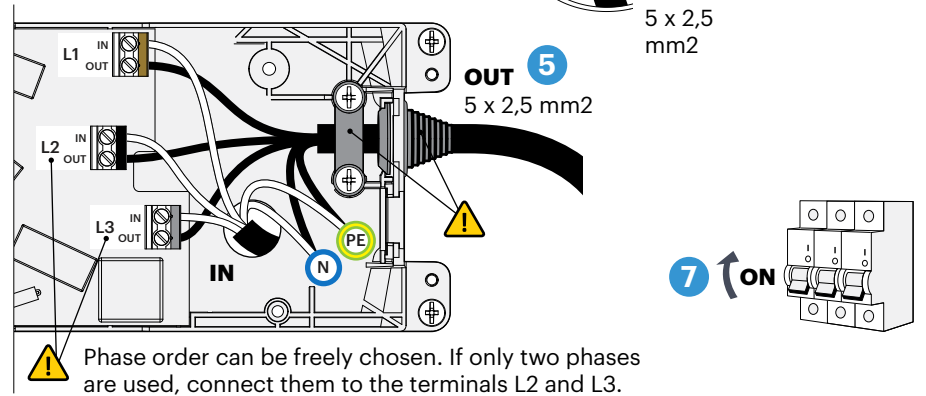

Phase order can be freely chosen. If only two phases are used, connect them to the terminals L2 and L3.

## PCU6.3-P - Installation

3-phase, Perilex-connectors.

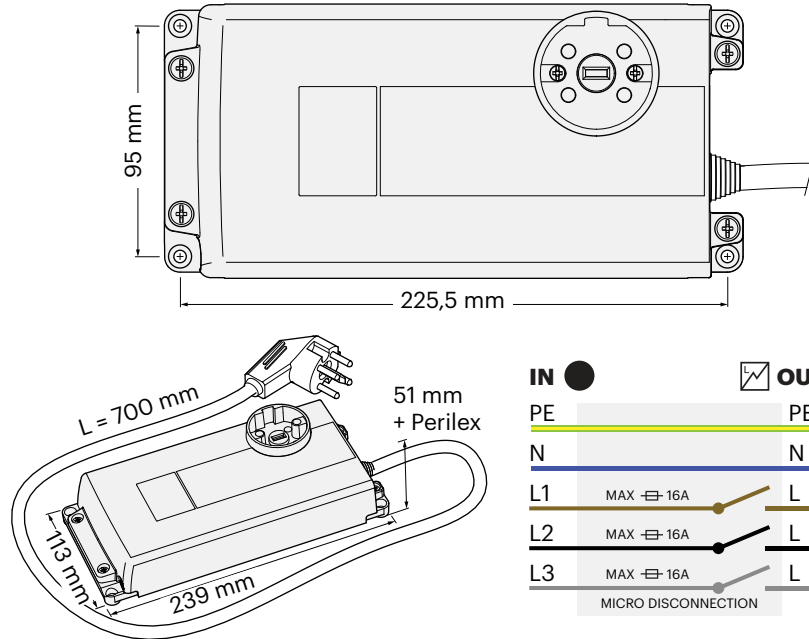

### ▲ WARNING

Make sure that there is no power supply to the cooker and the oven by removing their fuses. Also ensure that the cooker is switched off.

OUT-wires are always energized when the power control unit is connected to the electrical network. If a wire is loose, it must be properly covered.

Do not install the power control unit to excessive heat: See operational ambient temperature on the power control unit ©.

### ▮ ATTENTION

Install the power control unit © so that it is not exposed to moisture. Check that all cables can move freely.

If you are replacing the cooker or the power control unit, see chapter 4 manual adjustment mode.

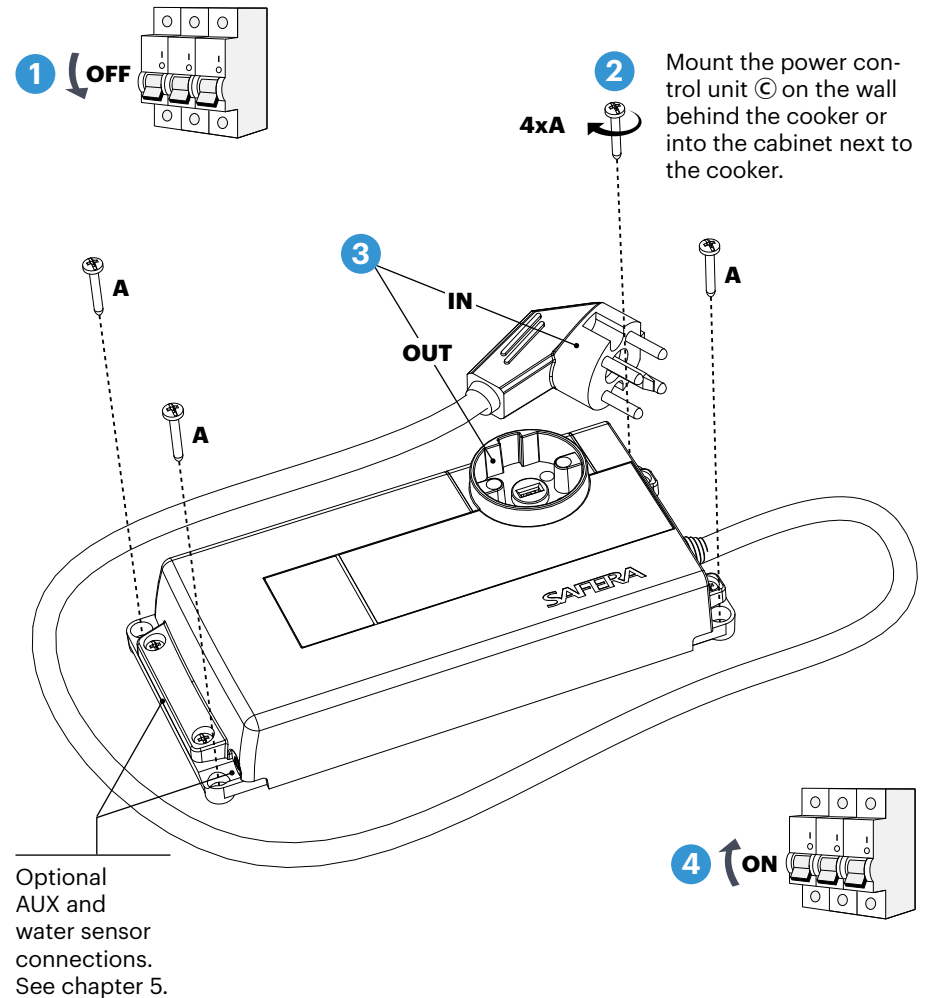

## PCU6.1-F - Installation

Fixed 1-phase connection.

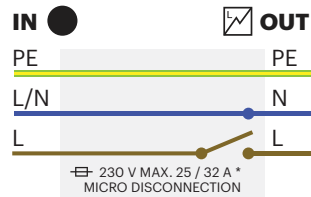
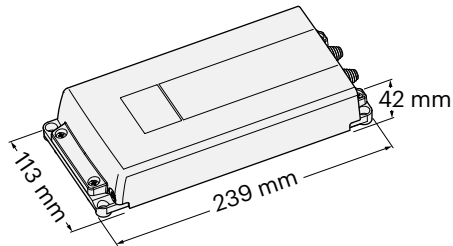
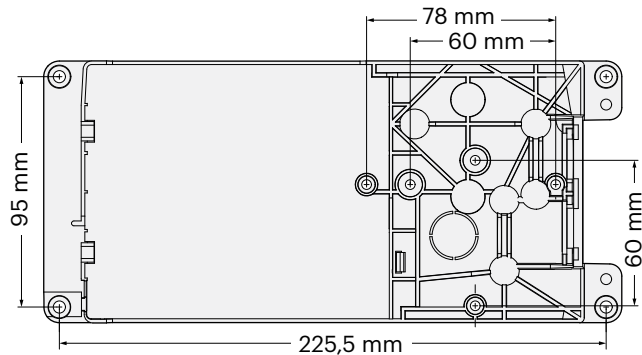

\* Check specifications on the cover of the Power Control Unit.

### ▲ WARNING

Make sure that there is no power supply to the cooker and the oven by removing their fuses. Also ensure that the cooker is switched off.

OUT-wires are always energized when the power control unit is connected to the electrical network. If a wire is loose, it must be properly covered.

Do not install the power control unit to excessive heat: See operational ambient temperature on the power control unit ☺.

### ▢ ATTENTION

Install the power control unit ☺ so that it is not exposed to moisture. Check that all cables can move freely.

If you are replacing the cooker or the power control unit, see chapter 4 manual adjustment mode.

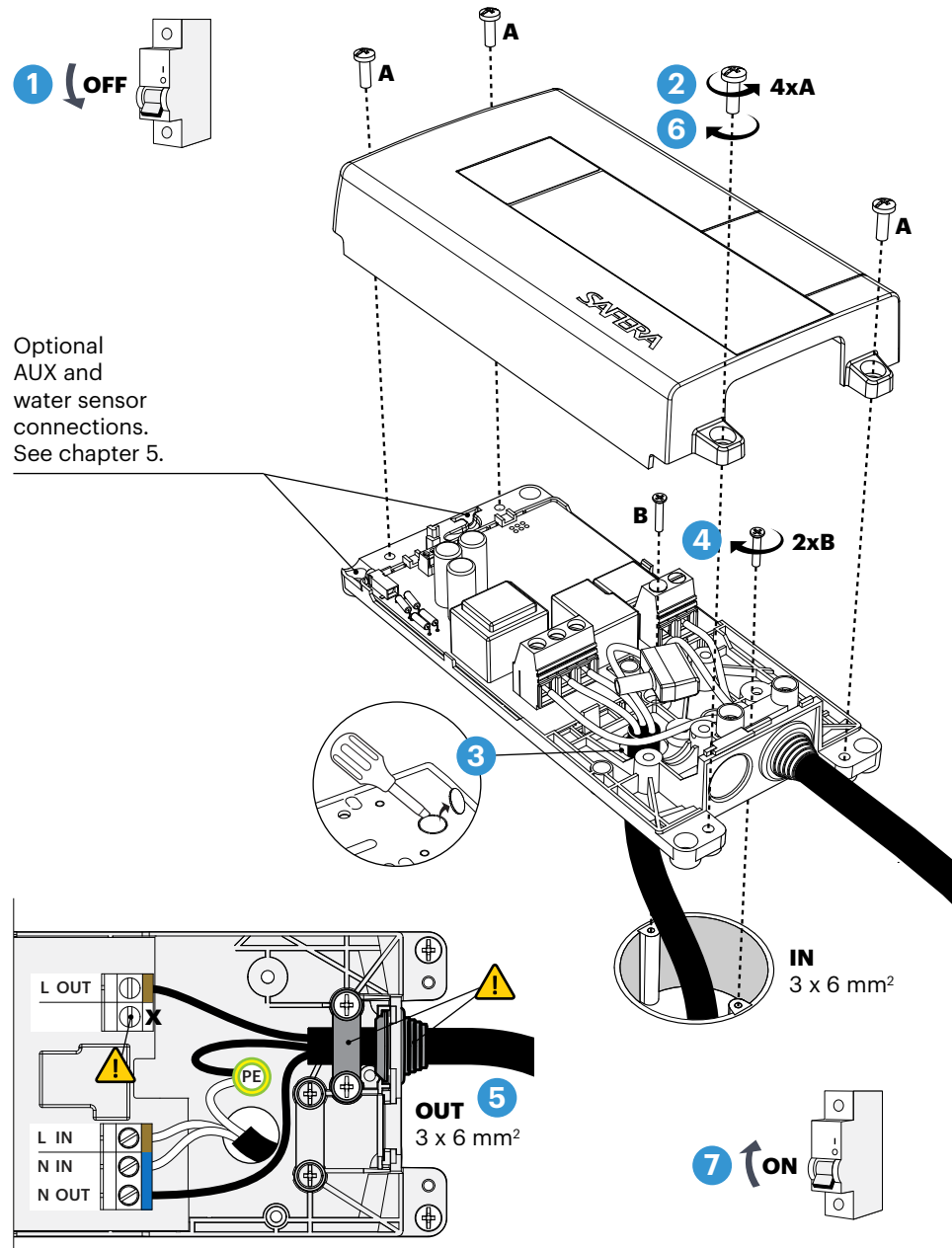

## PCU6.1-P - Installation

1-phase, 3-pin plug.

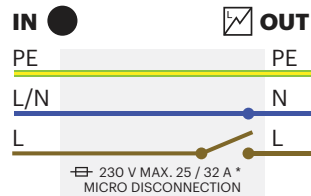
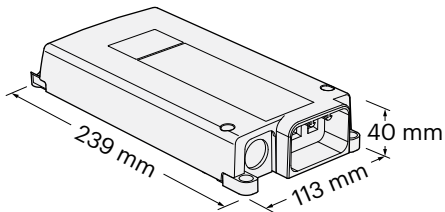
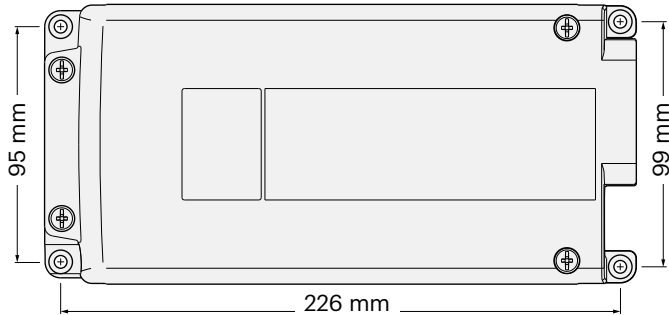

\* Check specifications on the cover of the Power Control Unit.

### ▲ WARNING

Make sure that there is no power supply to the cooker and the oven by removing their fuses. Also ensure that the cooker is switched off.

OUT-wires are always energized when the power control unit is connected to the electrical network. If a wire is loose, it must be properly covered.

Do not install the power control unit to excessive heat: See operational ambient temperature on the power control unit ©.

### ⚠ ATTENTION

Install the power control unit © so that it is not exposed to moisture. Check that all cables can move freely.

If you are replacing the cooker or the power control unit, see chapter 4 manual adjustment mode.

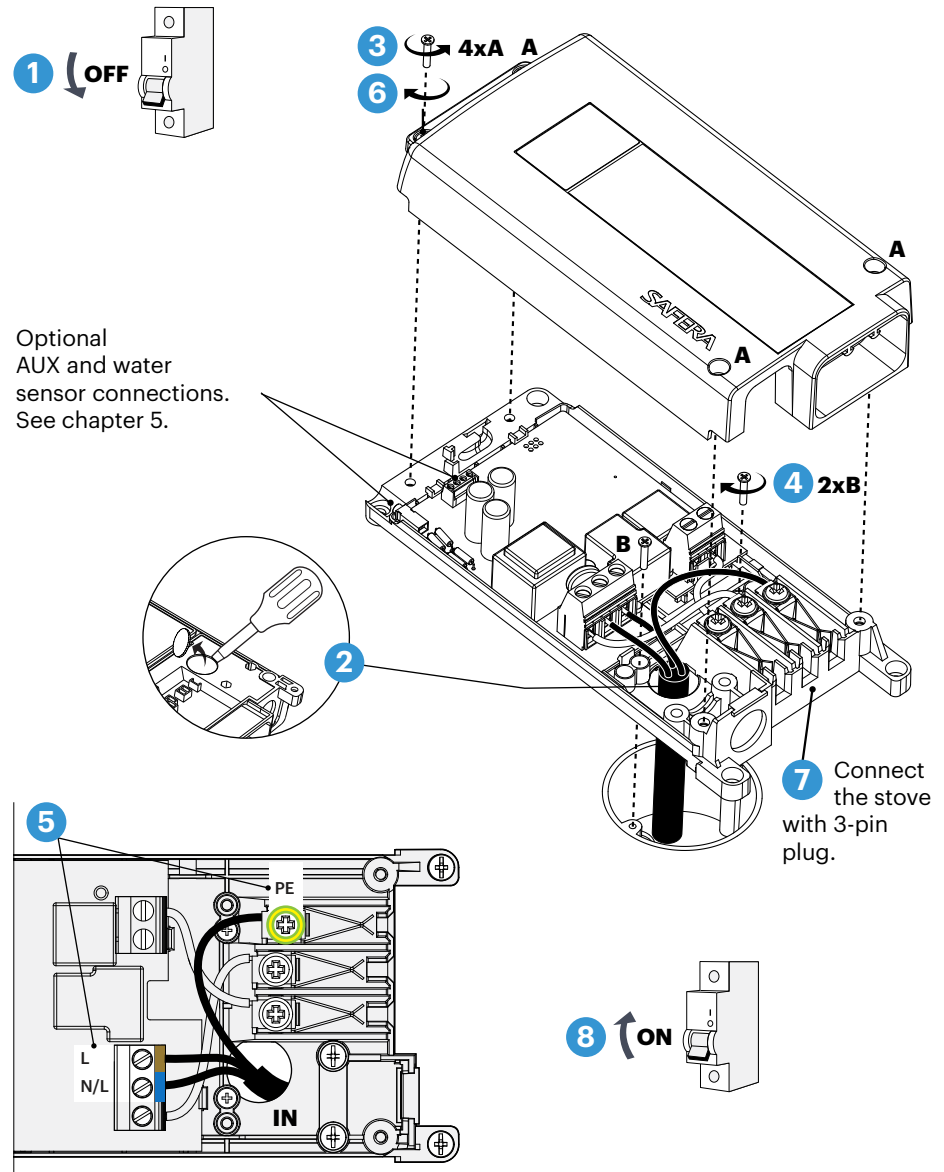

## PCU6.1-S - Installation

1-phase, Schuko-connectors.

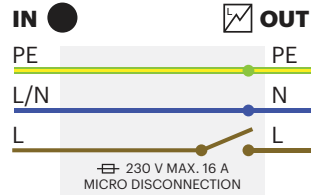
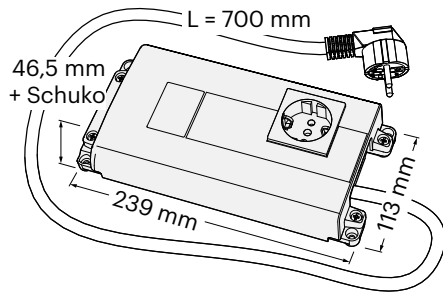
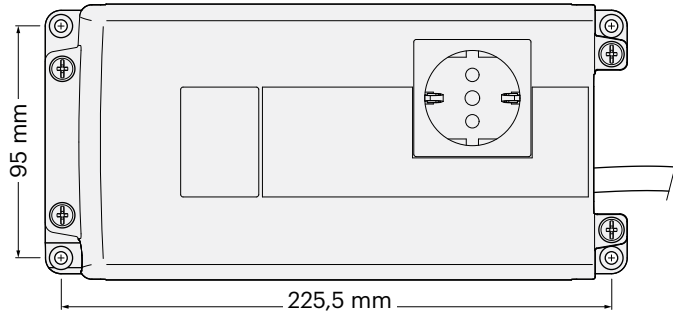

### ▲ WARNING

Make sure that there is no power supply to the cooker and the oven by removing their fuses. Also ensure that the cooker is switched off.

OUT-wires are always energized when the power control unit is connected to the electrical network. If a wire is loose, it must be properly covered.

Do not install the power control unit to excessive heat: See operational ambient temperature on the power control unit ©.

### ⚠ ATTENTION

Install the power control unit © so that it is not exposed to moisture. Check that all cables can move freely.

If you are replacing the cooker or the power control unit, see chapter 4 manual adjustment mode.

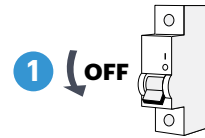

1 OFF

2 Mount the power control unit © on the wall behind the cooker or into the cabinet next to the cooker.

4xA

Optional AUX and water sensor connections. See chapter 5.

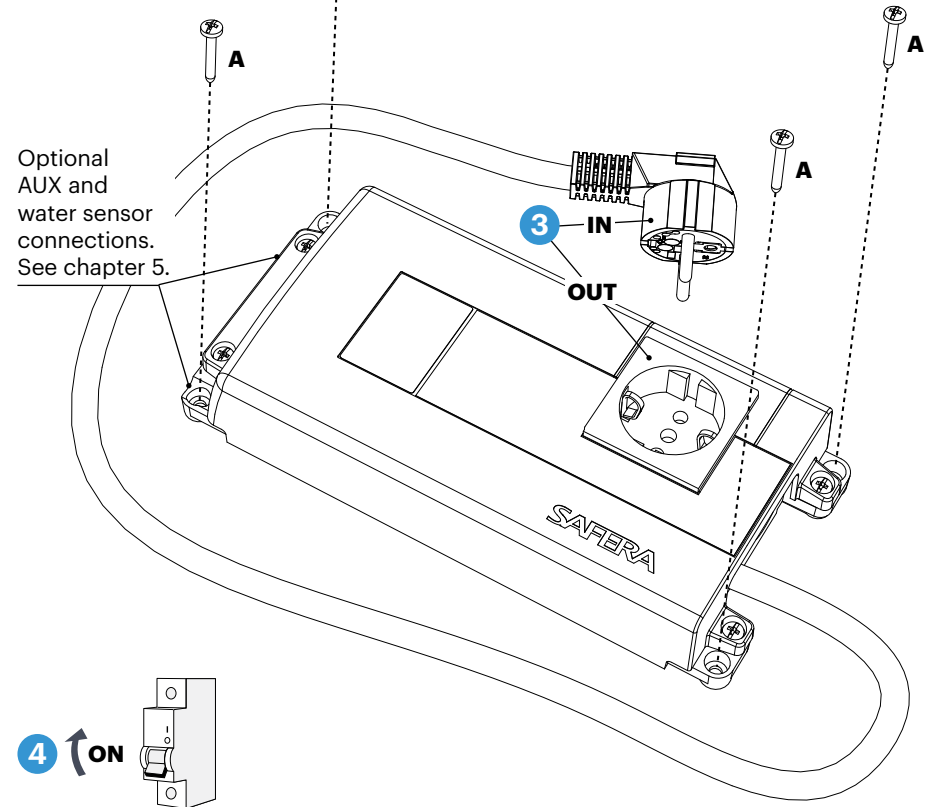

4 ON

## 1 Install the batteries



Place the batteries in the sensor unit **A** which should beep twice to indicate that the wireless connection to the Power Control Unit **C** was successful.

### ATTENTION

Check the correct position of the batteries marked on the bottom of the battery case.

## 2 Remove the protection strip from the adhesive tape



## 3 Mount the sensor unit **A**

- Use the cleaning pad to remove grease and dirt from the surface before attaching the sensor unit **A** with the adhesive tape.
- Mount the sensor unit **A** according to the mounting option A, B or C shown on the right: if the cooker width is 70 - 90 cm, lower the alarm limit one step compared to the recommended setting (see chapter 4.1.).

### ATTENTION

Ensure the correct sensor direction: both sensors **6** should look towards the cooker. The sensor unit **A** should be mounted on the centerline of the cooker.

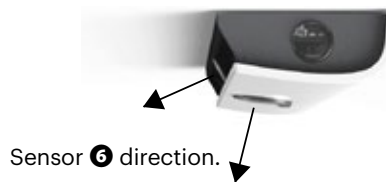

### Mounting option A: wall-mount

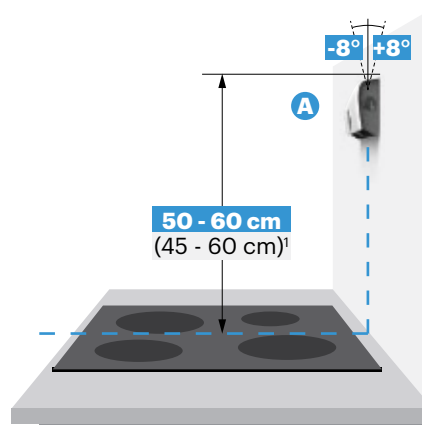

- 1) To install outside of the default installation height 50 - 60 cm, adjust the alarm limit according to chapter 4.

### Mounting option B and C: cooker hood

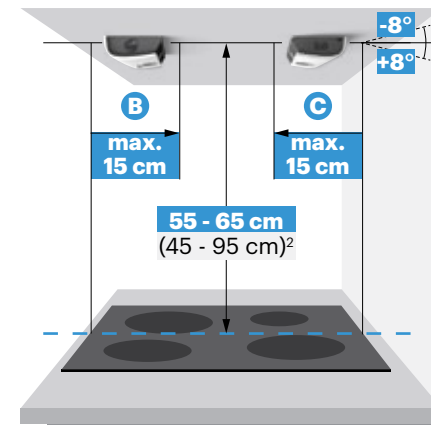

- 2) To install outside of the default installation height 55 - 65 cm, adjust the alarm limit according to chapter 4.

## 4 Check the working order

1. Turn on one cooker plate with maximum power. With an induction cooker use a suitable dish.
2. Press and hold the OK-button **5** for 5 seconds: the system should cut off the cooker power.
3. Test that none of the cooker plates and oven (if connected to the stove guard) are operable: if ok, switch off cooker and oven.
4. Return the cooker power by pressing the OK-button **3**: the Indicator Light **4** should blink green once. If not, see Troubleshooting in chapter 3.

5. Working order checked successfully:

Date \_\_\_\_\_ Installer \_\_\_\_\_

### HINT

Airis will automatically recognize the cooker type during cooking to minimize false alarms: to speed up the auto-recognition, you may manually select the cooker type according to the chapter 4.3.

### 3. Installation troubleshooting

Problem	Remedy
Problems with checking the working order: the cooker power does not shut down	<ul style="list-style-type: none"> <li>• Retry with the same cooker plate and ensure that the plate is set on highest power level.</li> <li>• With an induction cooker use a suitable dish so that the cooker is consuming power.</li> <li>• Check all wiring of the Power control unit ③.</li> </ul>
Cooker cannot be turned on after pressing the OK button ③.	<p>See user manual chapters 3.2 or 3.3. If the problem persists, the appliance might be faulty. Press the OK button ③ to find out the problem type by the indicator light ④:</p> <p><b>Indicator light ④ blinks in blue:</b></p> <ul style="list-style-type: none"> <li>• Blinks once: Problem with wireless connection.</li> <li>• Blinks twice: Problem with power control unit ③.</li> <li>• Blinks three times: Power control unit ③ over-heating.</li> </ul> <p><b>Indicator light ④ blinks in yellow:</b></p> <ul style="list-style-type: none"> <li>• Blinks once: Problem with sensors ②.</li> <li>• Blinks twice: Problem with sensor unit ①</li> <li>• Blinks three times: Faulty installation position of the sensor unit ①</li> </ul>
Faulty installation position of the sensor unit ①.	<p>Sensor unit ① will automatically recognize its' installation position during the first time the cooker is used for cooking. After the auto-recognition is completed, the stove guard will prevent the use of cooker and oven if the sensor unit ① is removed from its' original installation position. To enable use of the cooker, place the sensor unit ① back to the mounting bracket ②. If the problem persists, the auto-recognition might not have been successful. Ensure the correct position of the sensor unit ① (see installation step 2/2) and manually reconnect the wireless connection according the installation manual chapter 4.2. The fault should be then reseted automatically in two minutes.</p>
The wireless connection is not working.	<p>Go into the Manual adjustment mode and set up the wireless connection manually, see chapter 4.</p>
The sensor unit ① is not responding to any button and none of the indicator lights are lit.	<p>Ensure that the batteries are not empty. Check the correct position of the batteries marked on the bottom of the battery case.</p>
The appliance turns off the power from the cooker, but the power comes back on immediately.	<p>Make sure that the power control unit ③ is connected correctly – in other words, the cooker is connected to the OUT cable.</p>

### 4. Manual adjustment mode

To enable the fast installation, the default settings of Safera Airis are suitable for the most typical installations. In case you need to install the sensor unit outside the default installation dimensions or replace the cooker, sensor unit or power control unit in the original installation, you need to enter the manual adjustment mode.

Press the adjustment button ② for 5 seconds and you will enter the manual adjustment mode 1. You may move to the next mode by pressing OK-button ③:

Mode	Setting	Indicator light ④
Mode 1	Alarm limit settings	Lit white
Mode 2	Manual setup of the wireless connection	Blinking purple-blue
Mode 3	Manual calibration of the cooker type	Blinking yellow-green
Mode 4	Testing and adjusting AUX-connection	Blinking white (normal AUX-mode), or Blinking red (inversed AUX-mode)

#### 4.1 Mode 1: Alarm limit settings

When the indicator light ④ will lit white, you may adjust the alarm limit:

1. Check the closest recommended alarm limit from the reference table 1 below.
2. Adjust the alarm limit accordingly (the default setting is 6):
  - You may raise the alarm limit (+1): press the adjustment button 2.
  - You may lower the alarm limit (-1): press the adjustment button 1.
3. After adjusting the the alarm limit, the new alarm limit is indicated as shown in the table 2 and the stove guard will automatically exit the manual adjustment mode.

To move to the manual adjustment mode 2 without changes in mode 1, press OK button ③.

**Table 1:** Recommended alarm limit reference table based on the location of the cooker and the installation height. The range is 1 - 12 (1 = reacts fastest, 12 = reacts slowest).

Recommended alarm limit	Installation height: Mounting on the wall	Installation height: Mounting under the cooker hood
3	-	85 - 95 cm
4	-	75 - 85 cm
5	45 - 50 cm	65 - 75 cm
6*	50 - 60 cm	55 - 65 cm
7	-	45 - 55 cm

\* default

**Table 2.** The new alarm limit is indicated as shown in the table below:

Color of the indicator light ④	Number of beeps	Alarm Limit
Red	... ...	12
	... ..	11
	... .	10
	...	9
	..	8
	.	7
Blue	... ...	6 (default)
	... ..	5
	... .	4
	...	3
	..	2
	.	1

**▲ WARNING**

Do not set the alarm limit higher than 8 during the installation. If the alarm limit is set too high, the appliance may fail to detect a hazardous situation in time.

If the stove guard gives false alarms repeatedly, the alarm limit should not be raised more than two steps from the recommended setting.

**4.2 Mode 2: Manual setup of the wireless connection**

When the indicator light ④ is blinking purple-blue, you may manually setup the wireless connection between the sensor unit ① and the power control unit ② for example when replacing either one of the units:

- Take off the fuses for the cooker and oven for 10 seconds
- Put the fuses back: the power control unit ② will now contact the sensor unit ① which gives a sound signal (•••) and the stove guard will automatically exit the manual adjustment mode.

To move to the manual adjustment mode 3 without changes in mode 2, press OK button ③.

**4.3 Mode 3: Manual calibration of the cooker type**

When the indicator light ④ is blinking yellow-green, you may manually calibrate the cooker type from the two options:

**Option 1:**

Cooker **and** oven are connected to the power control unit ②.

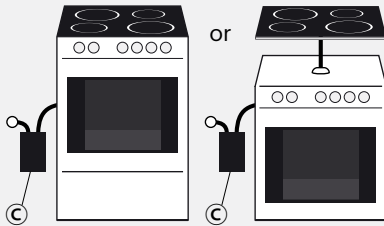

Turn on the oven and press the adjustment button ①. When you hear a sound signal, turn off the oven.

or

**Option 2:**

**Only** cooktop is connected to the power control unit ②.

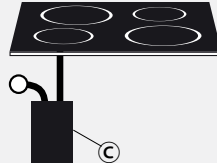

Turn on the biggest cooker plate with maximum power and press the adjustment button ②. When you hear a sound signal, turn off the cooker.

After calibration, the stove guard will automatically exit the manual adjustment mode.

To move to the manual adjustment mode 4 without changes in mode 3, press OK button ③.

**🔔 HINT**

With induction cooker, use a compatible dish.

## 4.4 Mode 4: Testing and adjusting AUX-connection

When the indicator light ④ is blinking white (normal AUX-mode) or a blinking red (inversed AUX-mode, see chapter 5.1.), you may:

- Test the AUX-connection:
  - Toggle the AUX1 output ON/OFF by pressing the Adjustment button ①
  - Toggle the AUX2 output ON/OFF by pressing the Adjustment button ②
- Toggle AUX-mode to "normal" or "inversed" by pressing and holding the Adjustment button ① for five seconds:
  - Normal AUX-mode selected: indicator light ④ blinks white
  - Inversed AUX-mode selected: indicator light ④ blinks red

To exit manual adjustment mode 4, press OK button ③ once. The stove guard and AUX signals will return to their normal operating state.

# 5. Optional features

## 5.1 AUX-connection (optional)

Safera PCU6.3 and PCU6.1 power control units ③ are equipped with two auxiliary output signals AUX1 and AUX2 compatible with most automation and security systems. They can be used to send real-time status information of the stove guard.

### 5.1.1 Electrical specifications

- Optoisolated and potential-free AUX-outputs: no galvanic connection between the Safera system and the automation system.
- When the AUX outputs are active (ON), the optoisolator's output transistors will be held in conducting mode, thus enabling current flow from IN to OUT. This connection can be used exactly as a relay's contact, however the direction and amount of the current flow must be controlled as specified below. If necessary, the output states can also be inverted (see chapter 5.1.6).
- Maximum IN-OUT voltage is 24 VDC.
- Maximum IN-OUT current is 10 mA.
- Only DC voltage between IN-OUT, no AC is permitted!

### 5.1.2 Coupling AUX-wire to the power control units PCU6.X

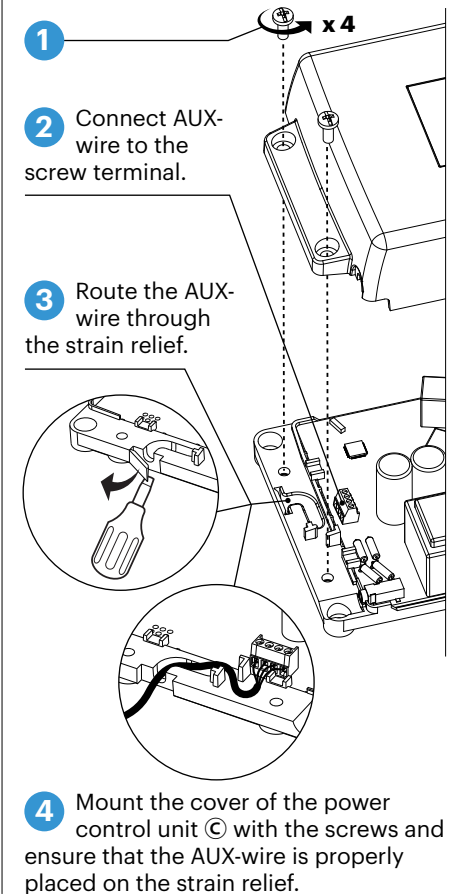

### 5.1.3 Example connection of one AUX-output

In this case the home automation system's logic input is pulled to ground potential when the AUX-output signal is active. Note that the maximum current pass in the optocoupler is 10 mA!

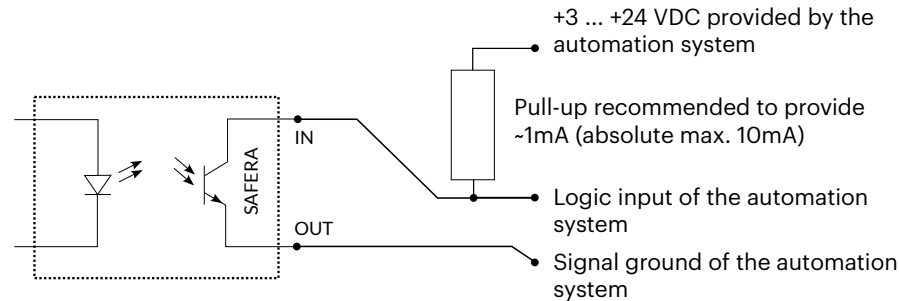

The diagram illustrates the connection of one AUX channel. AUX1 and AUX2 are similar.

#### **HINT**

Most building automation systems are equipped with inputs that are designed in a way that they do not need the pull-up resistors. One example of this kind of input is a 2-terminal input designed for connecting between relay contacts (potential free connection). In this kind of situation the AUX can usually be wired directly to the automation system. The only thing that must be observed is the current flow direction (IN > OUT) and that the current passing through must be limited to less than 10 mA by the automation system.

### 5.1.4 AUX-signal logic interpretation

The AUX-signals can be interpreted in many ways:

- Simple ON/OFF information for any type of alarm (heat, fire or water leak). This can be read directly from AUX1 output.
- Simple ON/OFF information for cooking activity. This can be read directly from AUX2 output.
- Simple ON/OFF information for a fault condition. This can be read directly when both AUX1 and AUX2 are connected in series to the same line.
- Four-state output according to the table below. This can be used by reading both AUX1 and AUX2 separately into the automation system and using internal logic to decide the state.

### 5.1.5 OUTPUT signals in normal AUX-mode

AUX1 state	AUX2 state	Safera system status
OFF	OFF	<b>Nothing to report</b> No active cooking or dangerous situation detected.
OFF	ON	<b>Normal cooking detected</b> This state will activate immediately when the stove is powered. It will turn off in roughly 1 to 30 minutes after the cooking has stopped, depending on how hot or powerful the cooking has been. This delay serves two purposes: 1) the signal can be used for optimally controlling the cooker hood fan or a kitchen extractor fan, and 2) the signal OFF->ON steps can be used for counting the amount of cooking processes.
ON	OFF	<b>Alarm</b> Dangerous situation detected: cooking hazard, timeout or extreme stove temperature has caused a power cutoff from the cooker. Also, water leakage alarm will trigger this state. This state will be cleared only when the user presses the OK-button of the Sensor Unit.
ON	ON	<b>Service needed</b> In most cases, power to the cooker has been cut off until the fault is resolved. This includes all critical Sensor Unit or Power Control Unit faults. Press the OK-button of the Sensor Unit to see the exact cause for the fault.

### 5.1.6 Inversed AUX-mode

Inversed AUX-mode = all ON signals indicated as OFF and vice versa in the table above.

Inversed signal mode can be useful for example when the maximum reliability for fault detection is needed: if the wires are broken, or all electricity is cut off, the output will be the same in as the AUX1:OFF & AUX2:OFF "fault condition".

#### **ATTENTION**

The inversed mode will create a larger load for the connected system, because both signals will be ON most of the time. For example, this may be harder for battery operated external clients. However, it will not affect the Safera system's own battery life.

## 5.2 Water leakage sensor (optional)

Stove Guard can be equipped with max. four Safera water leakage sensors. The sensors are placed in the typical leakage areas, e.g. under the dishwasher or sink.

- 1 Attach the sensors **F** in place.
- 2 Attach the plug **G** of the leakage sensor to the power control unit **H**.
- 3 If there is an extra sensor, its plug **G** is connected to the connector **I** of the previous sensor.
- 4 Check the operation of the furthest sensor **F** by placing a damp paper towel against it for 15 seconds. When the water is detected, the sensor unit **A** gives a sound signal and indicator light will blink in blue.
- 5 Reset the leakage alarm by pressing the OK button **B**. Clean and dry the sensor.

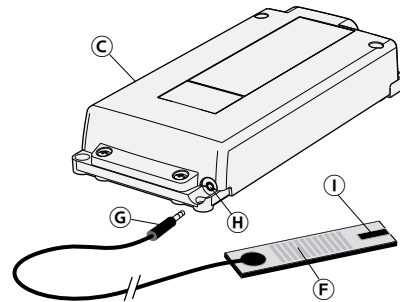
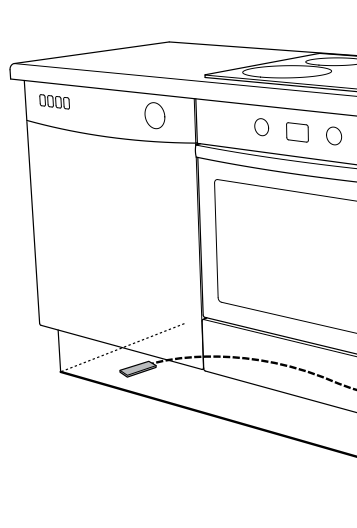

### **HINT**

If the sensor is left wet, the appliance will give another alarm in 8 hours after signing off the previous one.

