



PCU6.3-F



PCU6.1-F



PCU6.1-P



PCU6.3-P



PCU6.1-S

Installation manual

Safera Aurora Stove Guard



We sense what humans don't

Contents

1. Preparations
2. Installation
3. Installation Troubleshooting
4. Manual adjustment mode
5. Optional features

1. Preparations

Follow these instructions carefully and pay particular attention to the instructions marked in the following way:

WARNING

Follow instructions marked with a warning accurately to prevent injury to persons and damage to property.

ATTENTION

Follow instructions marked with a note carefully to prevent damage to property.

HINT

Hints give you useful advice on using the appliance.

1.1 Warnings

WARNING

Read user and installation manual before using or installing the appliance. Install and check the application according to the instructions. Safera is not liable for any damage or expenses caused by inappropriate installation.

Check that the Stove Guard is compatible with the cooker (see section 1.2).

If the connection cord is damaged, it must be replaced by the service personnel of the manufacturer or their representative to avoid hazards.

All electrical connections must be carried out by a qualified electrician.

ATTENTION

If the appliance was stored in a cold space, it must be allowed to warm up to room temperature before connecting it to mains power.

1.2 Compatibility

Safera Stove Guard is compatible with most electrical cookers, hobs and ovens meant for household use:

- Traditional cast-iron cookers and hobs
- Ceramic cookers and hobs
- Induction cookers and hobs
- Cookers and hobs equipped with a timer, afterheat indicator, child proof lock or integrated switch-off system

Safera Aurora is compatible with cookers no wider than 90 cm. See compatible kitchen layouts in chapter 2 and installation step 2/3.

1.3 Package content

Check the product and the contents of the package before installation:

Power control unit © (various models available)

Mounting screws (2x)



Remote control ④ with battery CR 2032

Sensor unit ① with mounting bracket ② and 4 x batteries (AA/LR6)

User and Installation Guides

- ① Adjustment button 1
- ② Adjustment button 2
- ③ OK-button
- ④ Indicator light
- ⑤ Mains voltage indicator (optional)
- ⑥ Sensors

HINT

The sensor unit and the remote control have identical button configurations so you may use either one to operate all functions of the stove guard.

WARNING

Please contact your vendor if you notice anything unusual about the appliance.



2. Installation - Step 1/3

Mount the Power Control Unit ©

Install the power control unit © according to the following instructions.

PCU6.3-F

Fixed 3-phase connection.
See pages 6-7.



PCU6.3-P

Perilex-connectors.
See pages 8-9.



PCU6.1-F

Fixed 1-phase connection.
See pages 10-11.



PCU6.1-P

1-phase, 3-pin plug OUT.
See pages 12-13.



PCU6.1-S

Schuko-connectors.
See pages 14-15.



PCU6.3-F - Installation

Fixed 3-phase connection.

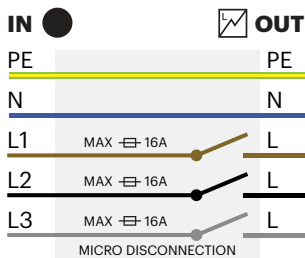
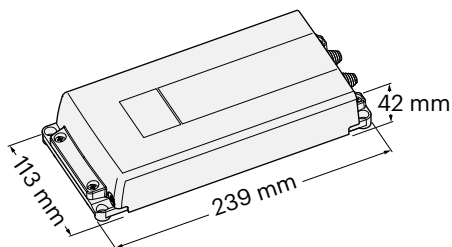
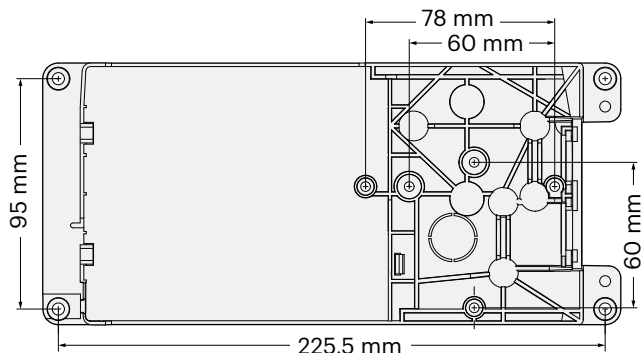

▲ WARNING

Make sure that there is no power supply to the cooker and the oven by removing their fuses. Also ensure that the cooker is switched off.

OUT-wires are always energized when the power control unit is connected to the mains power. If a wire is loose, it must be properly covered.

Do not install the power control unit where it will be exposed to excessive heat: See operational ambient temperature on the power control unit ©.

⚠ ATTENTION

Install the power control unit © so that it is not exposed to moisture. Check that all cables can move freely.

If you are replacing the cooker or the power control unit, see chapter 4 manual adjustment mode.

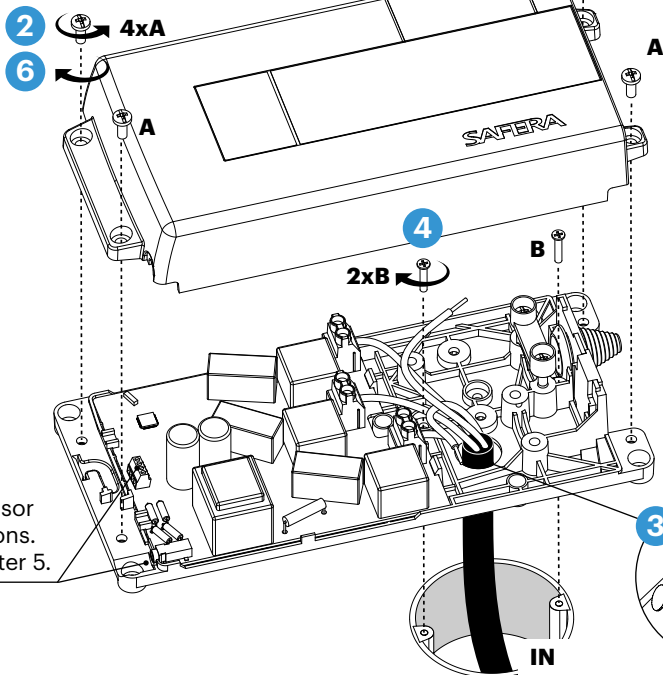
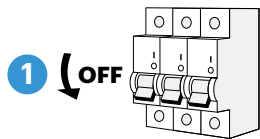

Optional
AUX and
water sensor
connections.
See chapter 5.

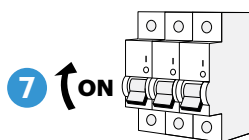
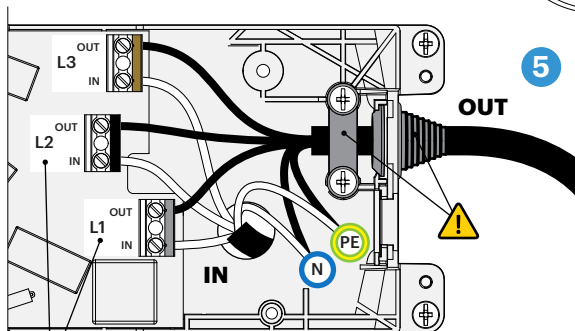

 Phase order can be freely chosen. If only two phases are used, connect them to the terminals L1 and L2.

PCU6.3-P - Installation

3-phase, Perilex-connectors.

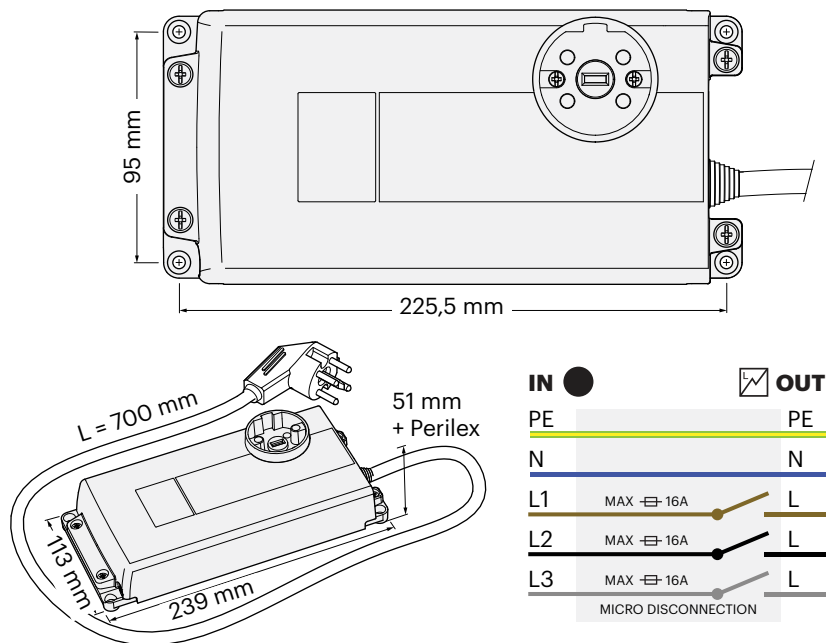

▲ WARNING

Make sure that there is no power supply to the cooker and the oven by removing their fuses. Also ensure that the cooker is switched off.

OUT-wires are always energized when the power control unit is connected to the mains power. If a wire is loose, it must be properly covered.

Do not install the power control unit where it will be exposed to excessive heat: See operational ambient temperature on the power control unit ©.

⚠ ATTENTION

Install the power control unit © so that it is not exposed to moisture. Check that all cables can move freely.

If you are replacing the cooker or the power control unit, see chapter 4 manual adjustment mode.

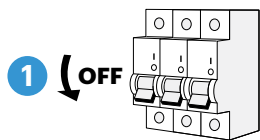

2 Mount the power control unit © on the wall behind the cooker or into the cabinet next to the cooker.

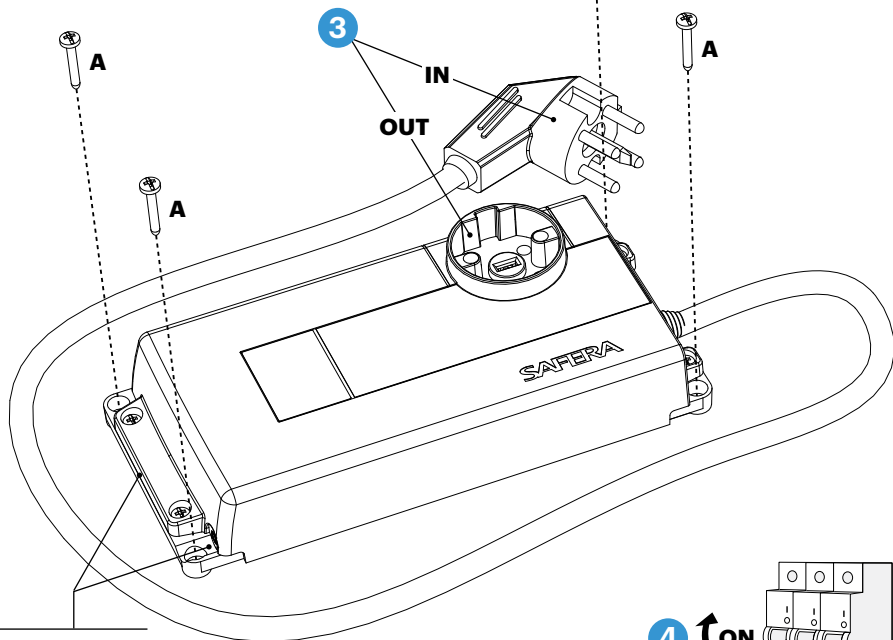

Optional
AUX and
water sensor
connections.
See chapter 5.

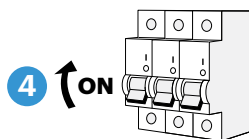

PCU6.1-F - Installation

Fixed 1-phase connection.

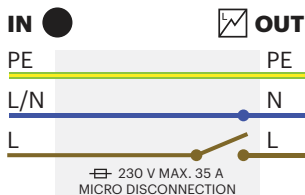
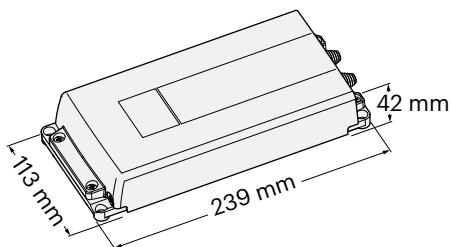
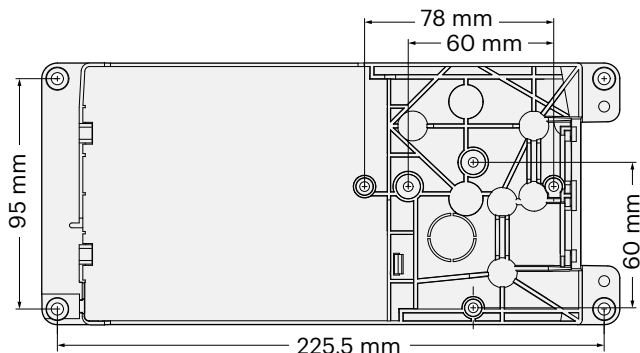

▲ WARNING

Make sure that there is no power supply to the cooker and the oven by removing their fuses. Also ensure that the cooker is switched off.

OUT-wires are always energized when the power control unit is connected to the mains power. If a wire is loose, it must be properly covered.

Do not install the power control unit where it will be exposed to excessive heat: See operational ambient temperature on the power control unit ©.

⚠ ATTENTION

Install the power control unit © so that it is not exposed to moisture. Check that all cables can move freely.

If you are replacing the cooker or the power control unit, see chapter 4 manual adjustment mode.

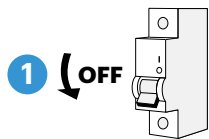

Optional
AUX and
water sensor
connections.
See chapter 5.

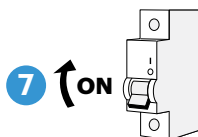
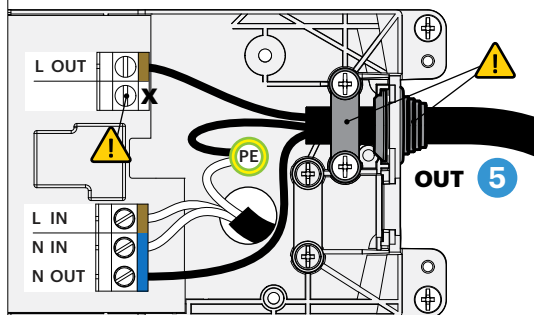
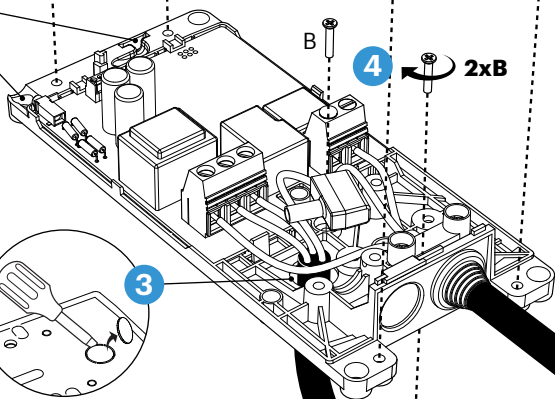
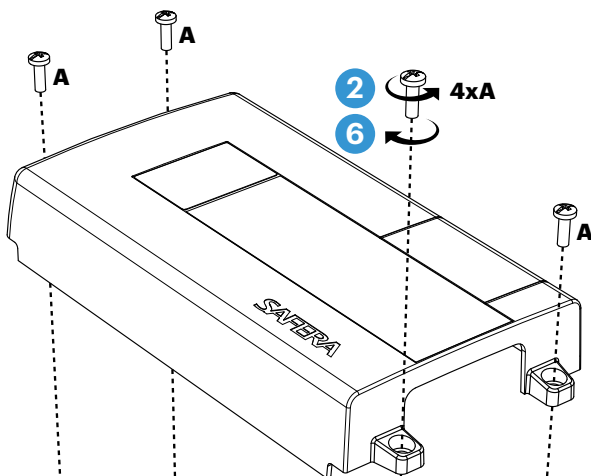

PCU6.1-P - Installation

1-phase, 3-pin plug.

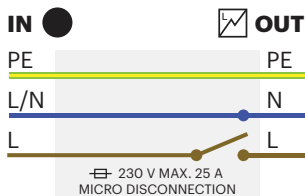
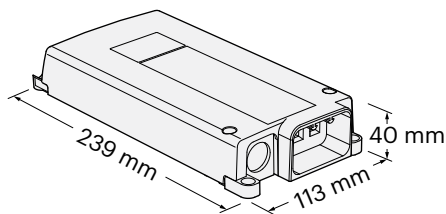
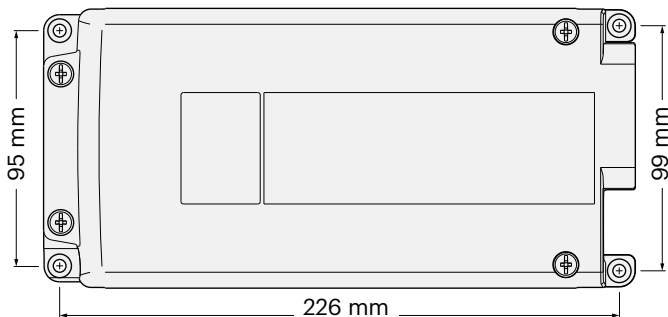

▲ WARNING

Make sure that there is no power supply to the cooker and the oven by removing their fuses. Also ensure that the cooker is switched off.

OUT-wires are always energized when the power control unit is connected to the mains power. If a wire is loose, it must be properly covered.

Do not install the power control unit where it will be exposed to excessive heat: See operational ambient temperature on the power control unit ©.

⚠ ATTENTION

Install the power control unit © so that it is not exposed to moisture. Check that all cables can move freely.

If you are replacing the cooker or the power control unit, see chapter 4 manual adjustment mode.

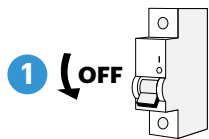

Optional
AUX and water
sensor connections.
See chapter 5.

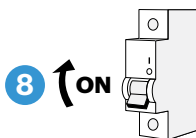
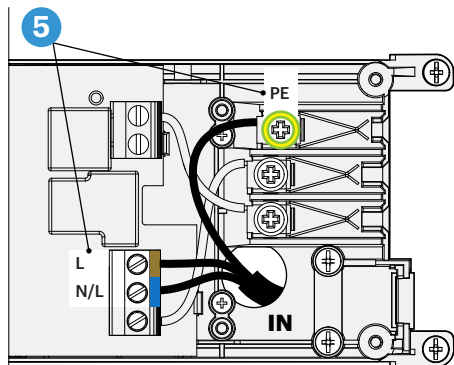
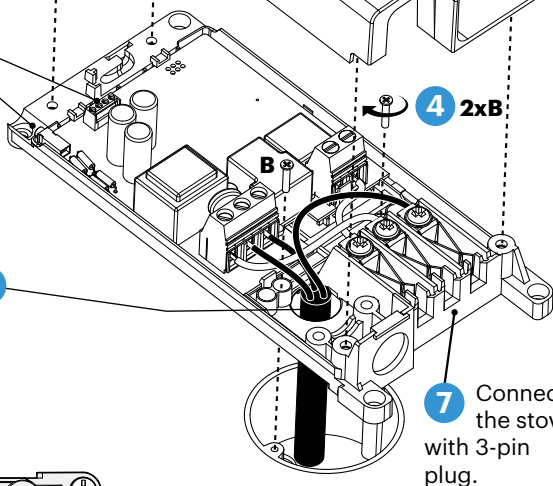
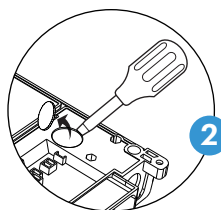
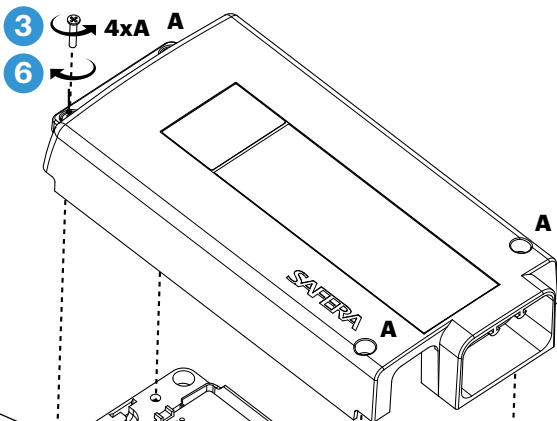

PCU6.1-S - Installation

1-phase, Schuko-connectors.

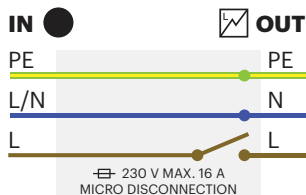
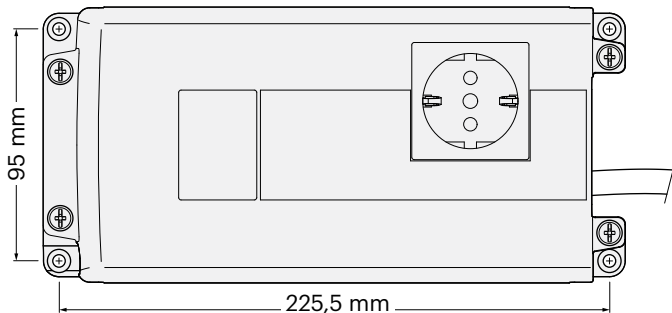

▲ WARNING

Make sure that there is no power supply to the cooker and the oven by removing their fuses. Also ensure that the cooker is switched off.

OUT-wires are always energized when the power control unit is connected to the mains power. If a wire is loose, it must be properly covered.

Do not install the power control unit where it will be exposed to excessive heat: See operational ambient temperature on the power control unit ©.

⚠ ATTENTION

Install the power control unit © so that it is not exposed to moisture. Check that all cables can move freely.

If you are replacing the cooker or the power control unit, see chapter 4 manual adjustment mode.

1 OFF

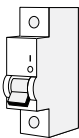

2

Mount the power control unit © on the wall behind the cooker or into the cabinet next to the cooker.

4xA

Optional
AUX and
water sensor
connections.
See chapter
5.

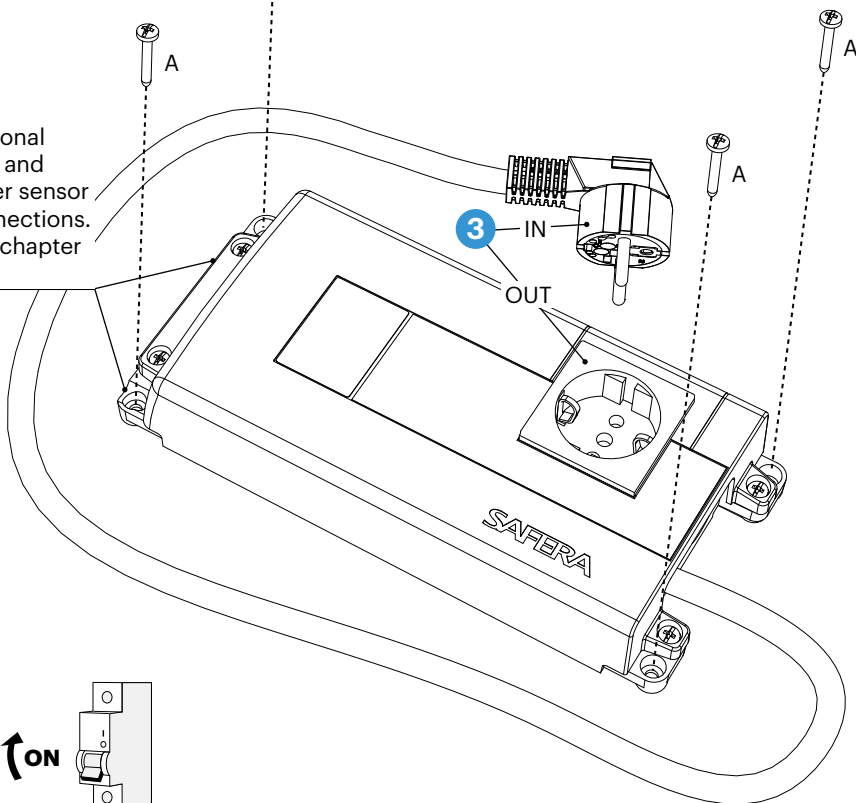

4 ON



2. Installation - Step 2/3

Mount the Sensor unit (A)

Notice the sensor direction and viewing angle:

▲ WARNING

Ensure that the sensor unit has clear line of sight to the whole cooktop and that there are no obstacles blocking its view. Incorrect installation may cause the stove guard not to react to cooking hazards.

Do not place hot items or other appliances with hot surfaces (e.g. toasters or grills) in close proximity of the cooktop, because they may interfere the sensor.

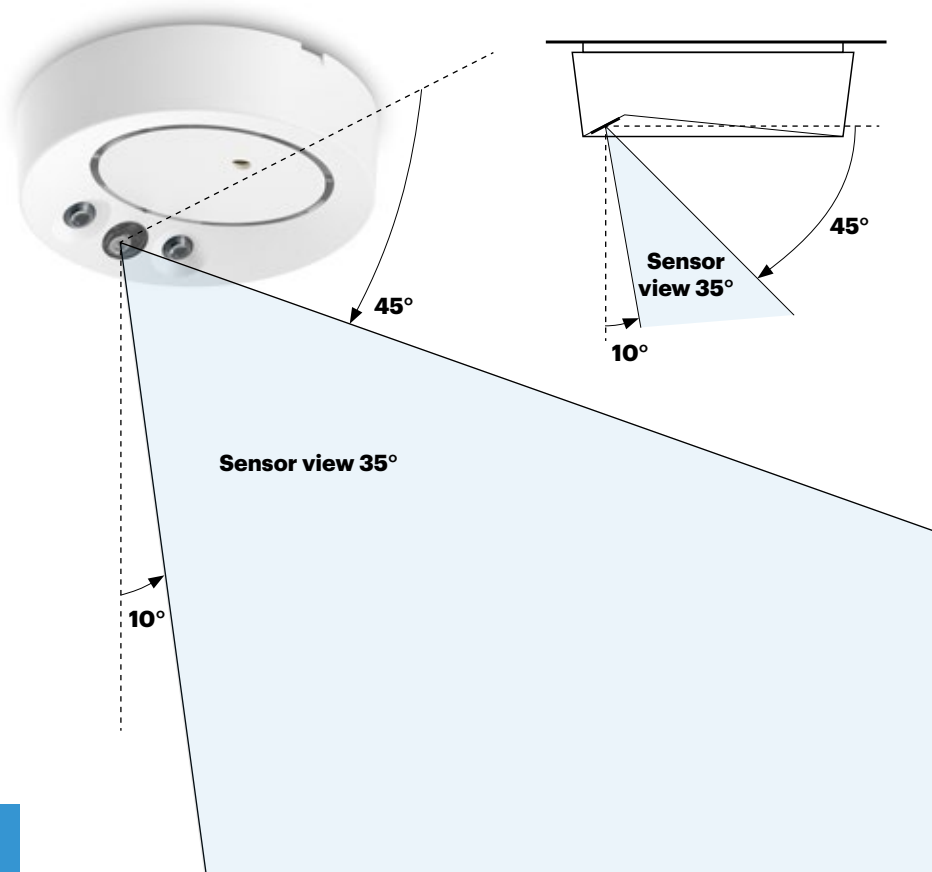

Ensure that there are no obstacles blocking the sensor view:

Example 1:

A tall object (e.g. downdraft hood) is blocking the sensor's sight to the cooktop.

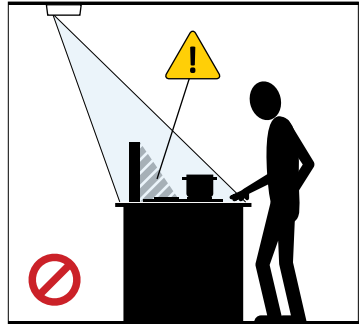

Example 2:

A cooker hood is blocking the sensor's sight to the cooktop.

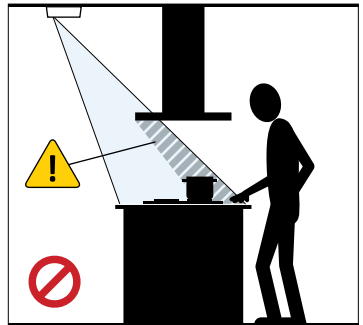

Example 3:

The user of the cooker is blocking the sensor's sight to the cooktop.

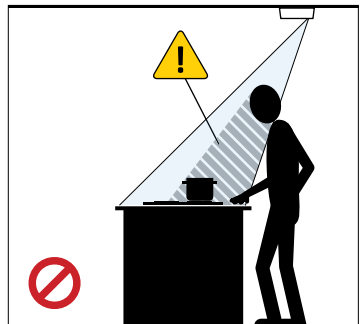

2. Installation - Step 2/3

Mount the Sensor unit (A)

Choose and follow the mounting instructions based on your kitchen ceiling angle:

Leveled ceiling 0...5°

If the ceiling in the kitchen is level, see installation instruction on pages 20-21.

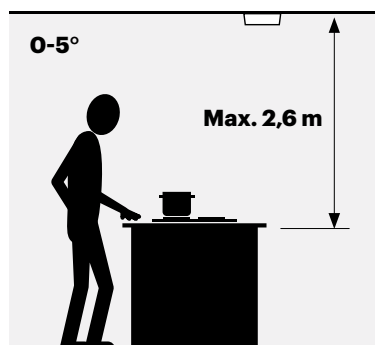

▲ WARNING

Safera Aurora is compatible with cookers no wider than 90 cm.

Sloped ceiling 5...18° (1:3)

If the ceiling in the kitchen is sloped, see installation instruction on pages 22-23.

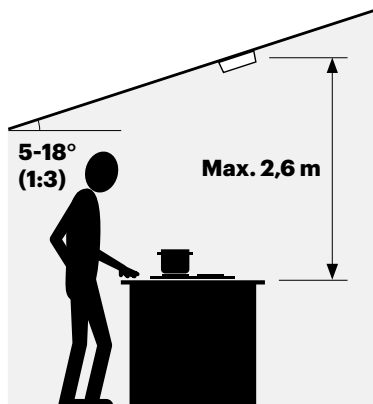

▲ WARNING

Safera Aurora is compatible with cookers no wider than 90 cm.

Sensor installation

Leveled ceiling 0...5°

Cooker width max. 90 cm

1 Mark the sensor unit's Ⓐ mounting location

1. Locate the spot (S) on the ceiling which is vertically directly above the cooktop center.
2. Measure the installation height (h).
3. Mark the sensor unit location e.g. the distance (r) from the center spot (S) on the ceiling according to the table below. The recommended location is on either side (0° or 180°) of the cooktop, see locations (a) or (b) in the picture below.

Height (h)	R min.	R recommended	R max.
1,4 - 1,8 m	0,5 m	0,7 m	0,9 m
1,8 - 2,1 m	0,5 m	0,7 m	1,3 m
2,1 - 2,6 m	0,6 m	0,7 m	1,6 m

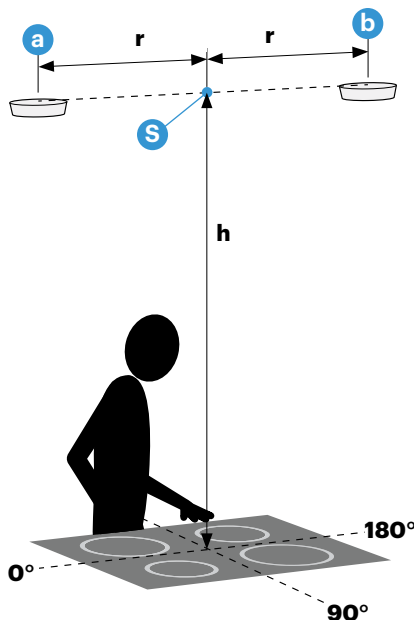

ATTENTION

It is recommended to mount the sensor unit perpendicular (e.g. 0°, 90°, 180° or 270°) to the cooktop. Other directions are also allowed but ensure that the sensor unit has clear sight to the cooktop even when someone is using the cooker.

2 Install the mounting bracket

1. Remove the mounting bracket **B** from the sensor unit **A** (see user manual 4.3).
2. Install the mounting bracket **B** in the selected mounting location and loosely tighten the mounting screws.
3. Point the arrow on the mounting bracket **B** towards the cooktop center.
4. Tighten the mounting screws.

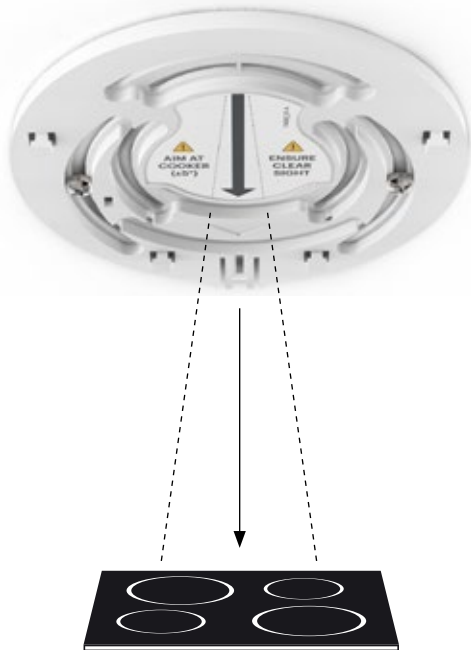

Sensor installation

Sloped ceiling 5...18° (1:3)
Cooker width max. 90 cm

1 Mark the sensor unit's **A** mounting location

1. Locate the spot (S) on the ceiling which is vertically directly above the cooktop center.
2. Mark the sensor unit location by measuring 0,35 m from the spot (S) upwards on the sloped ceiling.
3. Ensure that the vertical installation height (h) between the cooktop and the center of the mounting bracket **B** is not higher than 2,6 m.

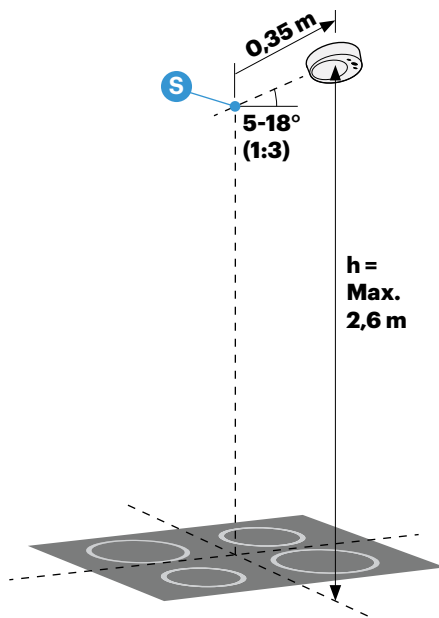

▲ WARNING

Maximum allowed ceiling slope is 18° (1:3).

2 Install the mounting bracket

1. Remove the mounting bracket **B** from the sensor unit **A** (see user manual 4.3).
2. Install the mounting bracket **B** in the selected mounting location and loosely tighten the mounting screws.
3. Point the arrow on the mounting bracket **B** towards the cooktop center.
4. Tighten the mounting screws.

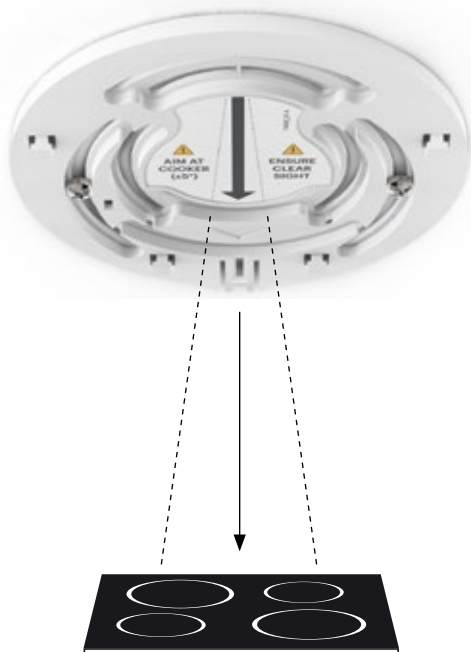

▲ WARNING

On a sloped ceiling the sensor unit must be directed so that the sensors and the arrow on the mounting bracket **B** are pointing downslope, see the picture on the right.

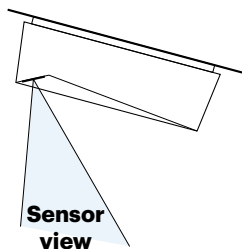

- 1 Remove the battery slip from the sensor unit **A**



- 2 Set the alarm limit according to the installation height

The default alarm limit setting is 8 (the range is 3-10) which is recommended for installation height 1,6 - 1,7 m.

You may adjust the alarm limit as follows:

1. Press the adjustment button **2** for 5 seconds and you will enter the manual adjustment mode 1: Alarm limit settings.
2. Set the alarm limit according to the chapter 4. Manual Adjustment Mode and Mode 1: Alarm limit settings.

HINT

Aurora will automatically recognize the cooker type during cooking to minimize false alarms: to speed up the auto-recognition, you may manually select the cooker type according to the chapter 4.3.

3 Mount the sensor unit (A) on the mounting bracket (B)

Mount the sensor unit (A) on the mounting bracket (B) by a) guiding it to the four pins and then b) sliding it gently until the unit is locked in the bracket.

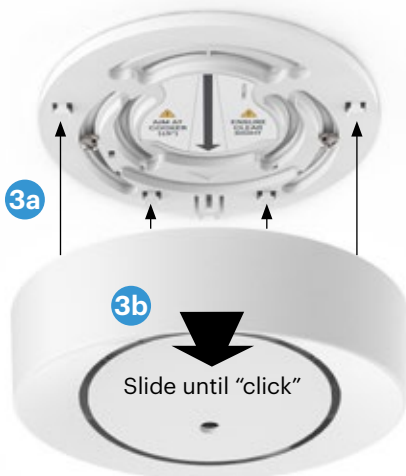

4 Check the working order

1. Ensure that the cooker is in room temperature.
2. Press the OK-button (3) for 3 seconds: the indicator light (4) starts blinking orange.
3. Place an empty pan on a cooking plate at medium to high power (e.g. 8/10).
4. Move at least two meters away from the cooker to avoid disturbing the test.
5. Wait maximum of two minutes that the sensor unit (A) gives an audible signal and indicates the test result
 - **Test was successful** if the indicator light (4) is blinking green and the cooker power has been switched off.
 - **Test was failed**
 - if the indicator light (4) is blinking red and if the cooker power is switched off: reinstall the sensor unit (A) so that it has a clear view on the cooktop
 - if the cooker power is not switched off in two minutes: turn off the cooker and check or reinstall the power control unit (C)
6. Press the OK-button (3) to finish the test.

Date _____ Installer _____

HINT

With induction cooker, use a compatible dish.

3. Installation Troubleshooting

Problems with checking the working order: the cooker power does not shut down

- Retry with the same cooker plate and ensure that the plate is set on highest power level.
- With an induction cooker use a suitable dish so that the cooker is consuming power.
- Check all wiring of the Power control unit (C).

Cooker cannot be turned on after pressing the OK button (E).

See user manual chapter 3.2. If the problem persists, the appliance might be faulty. Press the OK button (E) to find out the problem type by the indicator light (4):

Indicator light (4) blinks blue:

- Blinks once: Problem with wireless connection.
- Blinks twice: Problem with power control unit (C).
- Blinks three times: Power control unit (C) over-heating.

Indicator light (4) blinks yellow:

- Blinks once: Problem with sensors (G).
- Blinks twice: Problem with sensor unit (A).
- Blinks three times: Faulty installation position of the sensor unit (A)

Indicator light (4) blinks red:

- Blinks three times: Problem with mounting bracket (B).

Faulty installation position of the sensor unit (A).

Sensor unit (A) will automatically recognize its installation position during the first time the cooker is used for cooking. After the auto-recognition is completed, the stove guard will prevent the use of cooker and oven if the sensor unit (A) is removed from its original installation position. To enable use of the cooker, place the sensor unit (A) back to the mounting bracket (B). If the problem persists, the auto-recognition might not have been successful. Ensure the correct position of the sensor unit (A) (see installation step 2/3) and manually reconnect the wireless connection according to the installation manual chapter 4.2. The fault should be then corrected automatically in two minutes.

Faulty or old mounting bracket (B)

Sensor unit (A) is not installed properly into mounting bracket (B) or mounting bracket is old version. Remove it and changed the new one (included in package)

The wireless connection is not working.

Go into the Manual adjustment mode and set up the wireless connection manually, see chapter 4.2.

The sensor unit (A) is not responding to any button and none of the indicator lights are lit.

Ensure that the batteries are not empty. Check the correct position of the batteries marked on the bottom of the battery case.

The appliance turns off the power from the cooker, but the power comes back on immediately.

Make sure that the power control unit (C) is connected correctly – in other words, the cooker is connected to the OUT cable.

4. Manual adjustment mode

To enable the fast installation, the default settings of Safera Aurora are suitable for the most typical installations. In case you need to install the sensor unit outside the default installation dimensions or replace the cooker, sensor unit or power control unit in the original installation, you need to enter the manual adjustment mode.

Press the adjustment button **2** for 5 seconds and you will enter the manual adjustment mode 1. You may move to the next mode by pressing OK-button **3**:

Mode	Setting	Indicator light 4
Mode 1	Alarm limit settings	Lit white
Mode 2	Manual setup of the wireless connection	Blinking purple-blue
Mode 3	Manual calibration of the cooker type	Blinking yellow-green
Mode 4	Testing and adjusting AUX-connection	Blinking white (normal AUX-mode), or Blinking red (inversed AUX-mode)

4.1 Mode 1: Alarm limit settings

When the indicator light **4** is white, you may adjust the alarm limit.

1. Check the closest recommended alarm limit from the reference table 1 below.
2. Adjust the alarm limit accordingly (the default setting is 8):
 - You may raise the alarm limit (+1): press the adjustment button 2.
 - You may lower the alarm limit (-1): press the adjustment button 1.
3. After adjusting the alarm limit, the new alarm limit is indicated as shown in the table 2 and the stove guard will automatically exit the manual adjustment mode. To adjust the alarm limit more than one step re-enter to the manual adjustment mode.

To move to the manual adjustment mode 2 without changes in mode 1, press OK button **3**.

Table 1: Alarm limit settings.

Installation height (vertical distance between cooktop and sensor unit)	Recommended alarm limit
1,4 - 1,5 m	10
1,5 - 1,6 m	9
1,6 - 1,7 m	8*
1,7 - 1,8 m	7
1,8 - 1,9 m	6
2,0 - 2,1 m	5
2,1 - 2,3 m	4
2,3 - 2,6 m	3

* default

Table 2. The new alarm limit is indicated as shown in the table below:

Color of the indicator light ④	Number of beeps	Alarm Limit
Red	12
	11
	10
	...	9
	..	8 (default)
	.	7
Blue	6
	5
	4
	...	3
	..	2
	.	1

▲ WARNING

Do not set the alarm limit higher than 8 during the installation. If the alarm limit is set too high, the appliance may fail to detect a hazardous situation in time.

If the stove guard gives false alarms repeatedly, the alarm limit should not be raised more than two steps from the recommended setting.

4.2 Mode 2: Manual setup of the wireless connection

When the indicator light ④ is blinking purple-blue, you may manually setup the wireless connection between the sensor unit ① and the power control unit ③ for example when replacing either one of the units:

- Take off the fuses for the cooker and oven for 10 seconds
- Put the fuses back: the power control unit ③ will now contact the sensor unit ① which gives a sound signal (↔) and the stove guard will automatically exit the manual adjustment mode.

To move to the manual adjustment mode 3 without changes in mode 2, press OK button ③. After manual setup of the wireless connection, check the working order according to the user manual chapter 4.1.1.

4.3 Mode 3: Manual calibration of the cooker type

When the indicator light ④ is blinking yellow-green, you may manually calibrate the cooker type from the two options:

Option 1:

Cooker **and** oven are connected to the power control unit (C).

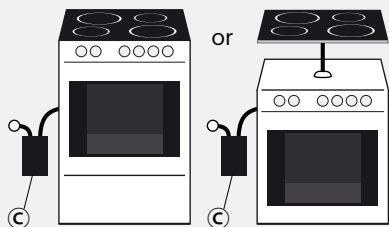

Turn on the oven and press the adjustment button ①. When you hear a sound signal, turn off the oven.

or

Option 2:

Only cooktop is connected to the power control unit (C).

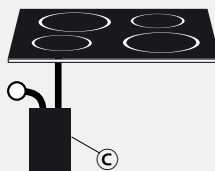

Turn on the biggest cooker plate with maximum power and press the adjustment button ②. When you hear a sound signal, turn off the cooker.

HINT

With induction cooker, use a compatible dish.

After calibration, the stove guard will automatically exit the manual adjustment mode.

To move to the manual adjustment mode 4 without changes in mode 3, press OK button ③. After manual calibration of the cooker type, check the working order according to the user manual chapter 4.1.1.

4.4 Mode 4: Testing and adjusting AUX-connection

When the indicator light ④ is blinking white (normal AUX-mode) or blinking red (inversed AUX-mode, see chapter 5.1.6), you may:

- Test the AUX-connection (default is OFF):
 - Toggle the AUX1 output ON/OFF by pressing the Adjustment button ①
 - Toggle the AUX2 output ON/OFF by pressing the Adjustment button ②
- Toggle AUX-mode to "normal" or "inversed" by pressing and holding the Adjustment button ① for five seconds:
 - Normal AUX-mode selected: indicator light ④ blinks white
 - Inversed AUX-mode selected: indicator light ④ blinks red

To exit manual adjustment mode 4, press OK button ③ once. The stove guard and AUX signals will return to their normal operating state.

5. Optional features

5.1 AUX-connection (optional)

Safera PCU6.3 and PCU6.1 power control units © are equipped with two auxiliary output signals AUX1 and AUX2 compatible with most automation and security systems. They can be used to send real-time status information of the stove guard.

5.1.1 Electrical specifications

- Optoisolated and potential-free AUX-outputs: no galvanic connection between the Safera system and the automation system.
- When the AUX outputs are active (ON), the optoisolator's output transistors will be held in conducting mode, thus enabling current flow from IN to OUT. This connection can be used exactly as a relay's contact, however the direction and amount of the current flow must be controlled as specified below. If necessary, the output states can also be inverted (see chapter 5.1.6).
- Maximum IN-OUT voltage is 24 VDC.
- Maximum IN-OUT current is 10 mA.
- Only DC voltage between IN-OUT, no AC is permitted!

5.1.2 Coupling AUX-wire to PCU6.3 and PCU6.1

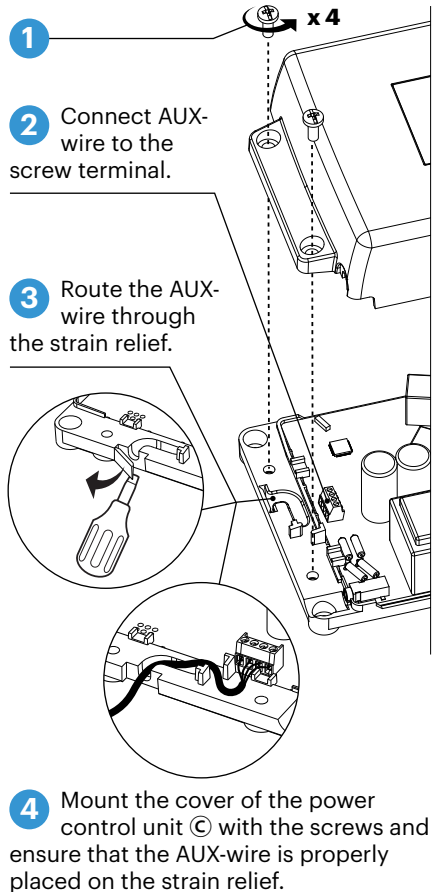

5.1.3 Example connection of one AUX-output

In this case the home automation system's logic input is pulled to ground potential when the AUX-output signal is active. Note that the maximum current pass in the optocoupler is 10 mA!

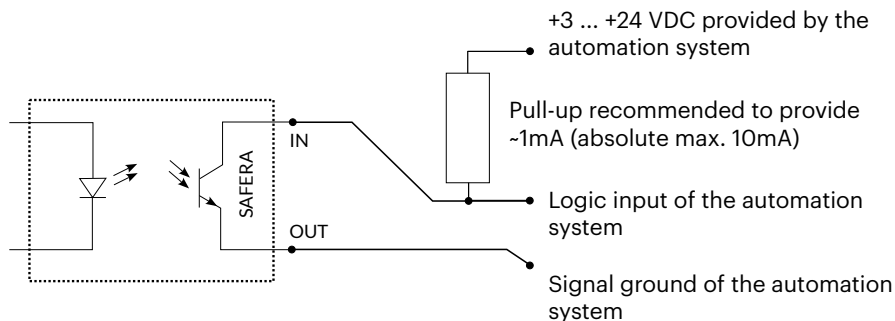

The diagram illustrates the connection of one AUX channel. AUX1 and AUX2 are similar.

HINT

Most building automation systems are equipped with inputs that are designed in a way that they do not need the pull-up resistors. One example of this kind of input is a 2-terminal input designed for connecting between relay contacts (potential free connection). In this kind of situation the AUX can usually be wired directly to the automation system. The only thing that must be observed is the current flow direction ($IN > OUT$) and that the current passing through must be limited to less than 10 mA by the automation system.

5.1.4 AUX-signal logic interpretation

The AUX-signals can be interpreted in many ways:

- Simple ON/OFF information for any type of alarm (heat, fire or water leak). This can be read directly from AUX1 output.
- Simple ON/OFF information for cooking activity. This can be read directly from AUX2 output.
- Simple ON/OFF information for a fault condition. This can be read directly when both AUX1 and AUX2 are connected in series to the same line.
- Four-state output according to the table below. This can be used by reading both AUX1 and AUX2 separately into the automation system and using internal logic to decide the state.

5.1.5 Output signals in normal AUX-mode

AUX1 state	AUX2 state	Safera system status
OFF	OFF	Nothing to report No active cooking or dangerous situation detected.
OFF	ON	Normal cooking detected This state will activate immediately when the stove is powered. It will turn off in roughly 1 to 30 minutes after the cooking has stopped, depending on how hot or powerful the cooking has been. This delay serves two purposes: 1) the signal can be used for optimally controlling the cooker hood fan or a kitchen extractor fan, and 2) the signal OFF->ON steps can be used for counting the amount of cooking processes.
ON	OFF	Alarm Dangerous situation detected: cooking hazard, timeout or extreme stove temperature has caused a power cutoff from the cooker. Also, water leakage alarm will trigger this state. This state will be cleared only when the user presses the OK-button of the Sensor Unit.
ON	ON	Service needed In most cases, power to the cooker has been cut off until the fault is resolved. This includes all critical Sensor Unit or Power Control Unit faults. Press the OK-button of the Sensor Unit to see the exact cause for the fault.

5.1.6 Inversed AUX-mode

Inversed AUX-mode = all ON signals indicated as OFF and vice versa in the table above.

Inversed signal mode can be useful for example when the maximum reliability for fault detection is needed: if the wires are broken, or all electricity is cut off, the output will be the same in as the AUX1:OFF & AUX2:OFF "fault condition".

ATTENTION

The inversed mode will create a larger load for the connected system, because both signals will be ON most of the time. For example, this may be harder for battery operated external clients. However, it will not affect the Safera system's own battery life.

5.2 Water leakage sensor (optional)

Stove Guard can be equipped with max. four Safera water leakage sensors. The sensors are placed in the typical leakage areas, e.g. under the dishwasher or sink.

- 1 Attach the sensors (F) in place.
- 2 Attach the plug (G) of the leakage sensor to the power control unit (H).
- 3 If there is an extra sensor, its plug (G) is connected to the connector (I) of the previous sensor.
- 4 Check the operation of the furthest sensor (F) by placing a damp paper towel against it for 15 seconds. When the water is detected, the sensor unit (A) gives a sound signal and indicator light will blink in blue.
- 5 Reset the leakage alarm by pressing the OK button (3). Clean and dry the sensor.

HINT

If the sensor is left wet, the appliance will give another alarm 8 hours after signing off the previous one.

